

NanoSpeed™ Broadband Variable Optical Attenuator (MMF Version, Bidirectional)



(Protected by U.S. patent 7,403,677B1 and pending patents)

DATASHEET

BUY NOW



Features

- Solid state
- High Reliability
- High Speed
- Broadband
- Bidirectional
- Low Insertion Loss
- Compact

Applications

- Power Control
- Power Regulation
- Power Balance
- Instrumentation

The Nano-speed Premium Variable Fiber Optical Attenuator (NPOA) provides electrical control of optical power. This is achieved using a patent pending non-mechanical configuration and activated via a voltage electrical control signal. The solid-state optical crystal design eliminates mechanical movement and organic materials. The NP Series Variable Optical Attenuators are designed to meet the most demanding operation requirements of ultra-high reliability and fast response time with minimal mechanical footprint. Agiltron also offers customized electronic designs to meet special control requirements and applications. The NPOA is bidirectional. The NP Series VOA is available in either normally-transparent in which the light passing through without the applying a voltage or normally-opaque in which the light is blocked without the applying of a voltage. The attenuation level is related to the stage. The response speed is related to the attenuation level and driver power (repetition rate). Small attenuation can reach MHz response.

The NP Series VOA is mounted on a specially designed electronic driving PCB board with a 0~5V control input and having performance optimized for various repetition rate.

Specifications

Parameter	Min	Typical	Max	Unit
Wavelength	1260		1625	nm
Insertion Loss ^[1]		1.2	1.5	dB
Polarization Dependent Loss		0.1	0.35	dB
Return Loss	45	50		dB
Attenuation Range	13			dB
Response Time (Rise, Fall)			300	ns
Repetition Rate ^[2]	DC	5	100	kHz
Resolution		Continuously		dB
Operating Optical Power			20	W
Operating Temperature		-5 ~ 70		°C
Storage Temperature		-40 ~ 85		°C

Notes:

[1]. Excluding connectors

[2]. 5kHz and 100kHz repeat rates are realized in the different drivers

[3]. Special circuit for narrow frequency range, maximum modulation depth is 5~10%

Warning: The device mounted on the PCB is an OEM module designed for system integration only, not for general uses. Do not touch the PCB by hand. The electrical static can kill the chips even without a power plug-in, and unpleasant electrical shock may also be felt. For laboratory use, please buy a protected Turnkey system.

Legal notices: All product information is believed to be accurate and is subject to change without notice. Information contained herein shall legally bind Agiltron only if it is specifically incorporated into the terms and conditions of a sales agreement. Some specific combinations of options may not be available. The user assumes all risks and liability whatsoever in connection with the use of a product or its application.

Rev 02/02/24

© Photonwares Corporation

P +1 781-935-1200

E sales@photonwares.com

W www.agiltron.com

Information contained herein is deemed to be reliable and accurate as of the issue date. Photonwares reserves the right to change the design or specifications at any time without notice. Agiltron is a registered trademark of Photonwares Corporation in the U.S. and other countries.

NanoSpeed™ Broadband Variable Optical Attenuator (MMF Version, Bidirectional)



(Protected by U.S. patent 7,403,677B1 and pending patents)

DATASHEET

Mechanical Dimensions (mm)

Output (Blue) Input (White)

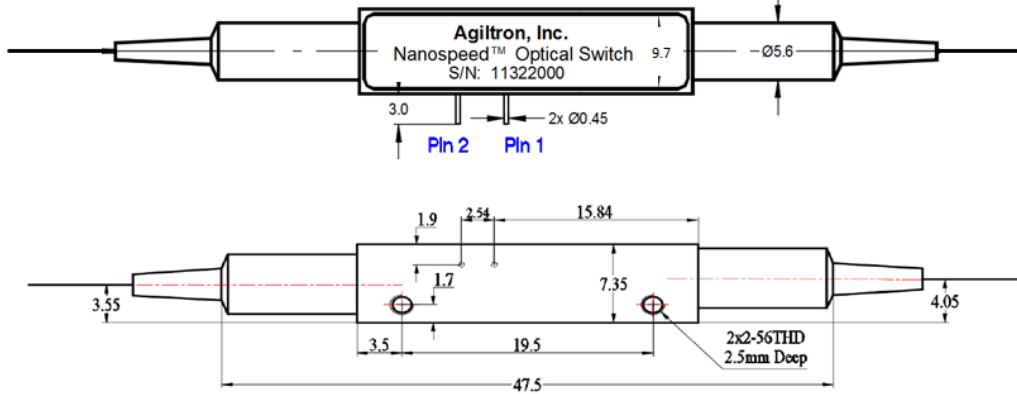

Normal Power VOA

Input (White) Output (Blue)

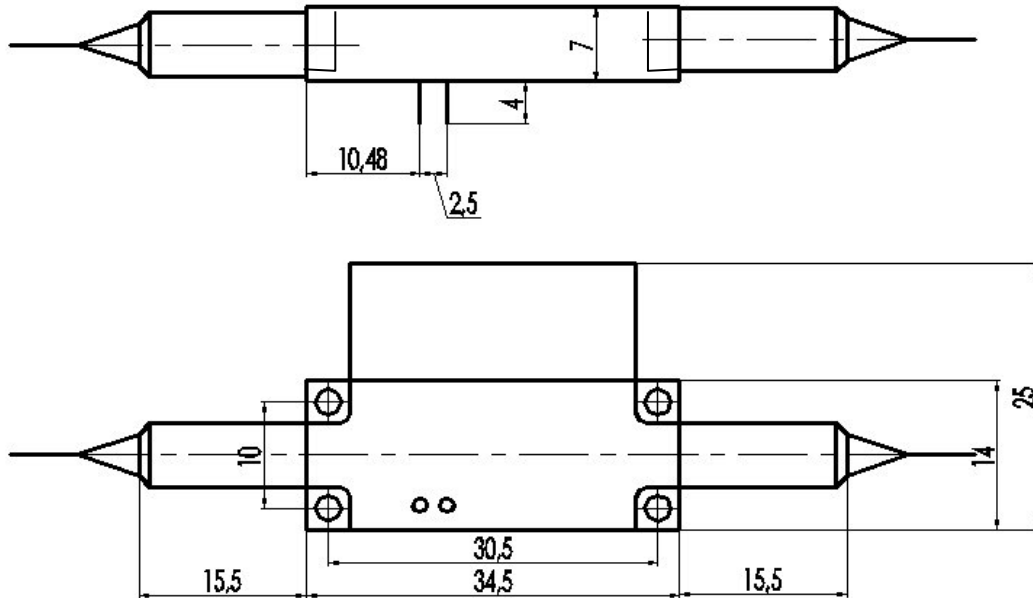

High Power VOA

*Product dimensions may change without notice. This is sometimes required for non-standard specifications.

NanoSpeed™ Broadband Variable Optical Attenuator (MMF Version, Bidirectional)



(Protected by U.S. patent 7,403,677B1 and pending patents)

DATASHEET

Typical Speed and Repetition Measurement

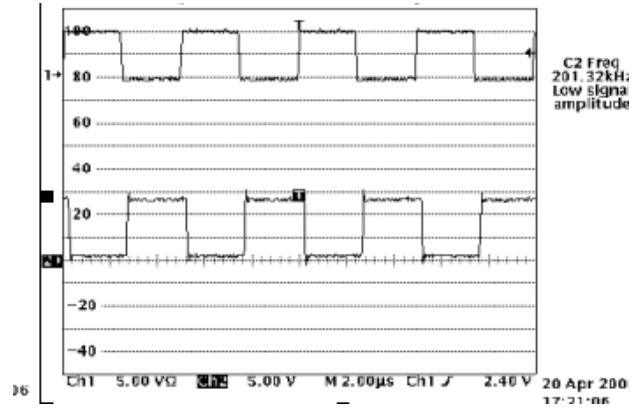
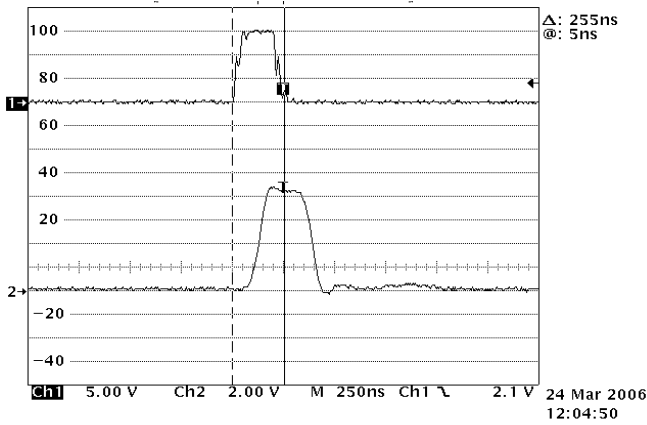

Typical Attenuation versus Voltage

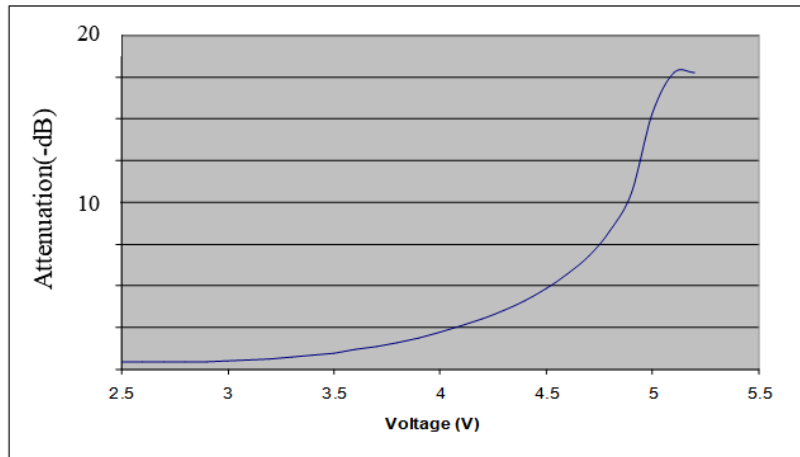

Note: For customers that prefer to design their own driving circuit, they are responsible for the optical performance. For more technical information, please contact us.

Driving Board Selection

Maximum Repetition Rate	Part Number (P/N)
5 kHz	NVDR-111221112
20 kHz	NVDR-113235112
100 kHz	NVDR-112221112

Note: For customers that prefer to design their own driving circuit, they are responsible for the optical performance. For more technical information, please contact us.

NanoSpeed™ Broadband Variable Optical Attenuator (MMF Version, Bidirectional)



(Protected by U.S. patent 7,403,677B1 and pending patents)

DATASHEET

Specify wavelength dependent loss @10dB attenuation

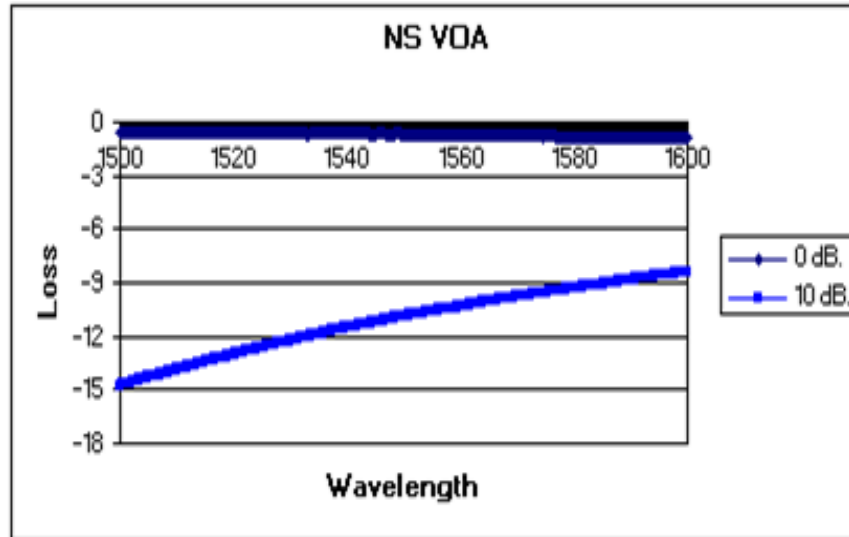

Ordering Information

Prefix	Type	Wavelength	State	Optical Power	Fiber Type	Fiber Cover	Fiber Length	Connector
NMOA-	Regular slope = 2	1260-1620nm = 1 Special = 0	Transparent = 1 Opaque = 2	500mW = 8 2W CW = 2 5W CW = 5 10W = 6 20W = 7	50/125 = 5 62.5/125 = 6 Special = 0	Bare fiber = 1 900um loose tube = 3 Special = 0	0.25m = 1 0.5m = 2 1.0 m = 3 Special = 0	None = 1 FC/PC = 2 FC/APC = 3 SC/PC = 4 SC/APC = 5 ST/PC = 6 LC/PC = 7 LC/APC = A LC/UPC = U Special = 0

NOTE:

“transparent” means no attenuation without applying a controlling voltage, the “opaque” means the highest attenuation without applying a controlling voltage.

NanoSpeed™ Broadband Variable Optical Attenuator (MMF Version, Bidirectional)



(Protected by U.S. patent 7,403,677B1 and pending patents)

DATASHEET

Q&A

Q: Does NS device drift over time and temperature?

A: NS devices are based on electro-optical crystal materials that can be influenced to a certain range by the environmental variations. The insertion loss of the device is only affected by the thermal expansion induced miss-alignment. For extended temperature operation, we offer special packaging to -40 ... 100 °C. The extinction or cross-talk value is affected by many EO material characters, including temperature-dependent birefringence, V_p , temperature gradient, optical power, at resonance points (electronic). However, the devices are designed to meet the minimum extinction/cross-talk stated on the spec sheets. It is important to avoid a temperature gradient along the device length.

Q: What is the actual applying voltage on the device?

A: 100 to 400V depending on the version.

Q: How does the device work?

A: NS devices are not based on Mach-Zander Interference, rather birefringence crystal's nature beam displacement, in which the crystal creates two different paths for beams with different polarization orientations.

Q: What is the limitation for faster operation?

A: NS devices have been tested to have an optical response of about 300 ps. However, practical implementation limits the response speeds. It is possible to achieve a much faster response when operated at partial extinction value. We also offer resonance devices over 20MHz with low electrical power consumption.

Operation Manual

1. Connect a control signal to the SMA connector on the PCB.
2. Attach the accompanied power supply (typically a wall-pluggable unit).
3. The device should then function properly.

Note: Do not alter device factory settings.

Application Notes

Fiber Core Alignment

Note that the minimum attenuation for these devices depends on excellent core-to-core alignment when the connectors are mated. This is crucial for shorter wavelengths with smaller fiber core diameters that can increase the loss of many decibels above the specification if they are not perfectly aligned. Different vendors' connectors may not mate well with each other, especially for angled APC.

Fiber Cleanliness

Fibers with smaller core diameters (<5 μm) must be kept extremely clean, contamination at fiber-fiber interfaces, combined with the high optical power density, can lead to significant optical damage. This type of damage usually requires re-polishing or replacement of the connector.

Maximum Optical Input Power

Due to their small fiber core diameters for short wavelength and high photon energies, the damage thresholds for device is substantially reduced than the common 1550nm fiber. To avoid damage to the exposed fiber end faces and internal components, the optical input power should never exceed 20 mW for wavelengths shorter 650nm. We produce a special version to increase the how handling by expanding the core side at the fiber ends.